DATE

19/10/2017

AUTHOR

Fu Bo
Product Manager Projection
bo.fu@barco.com

Whitepaper

High-brightness projectors for outdoor projection

Introduction

All around the world, projection mapping is bringing smiles to people's faces. Not only does it transform a city's atmosphere by adding gorgeous colours to famous or everyday buildings, it also shares compelling stories and enriches the lives of spectators. With their easy installation and powerful level of illumination, high-brightness projectors have become the solution of choice for projection mapping projects. In this white paper, the focus is on projection and the elements required providing a stunning visual experience on any canvas, being it a building, waterfall or even a hot air balloon.



Villa Médici, pictures courtesy of Spectaculaires

Why use high-brightness projection?

Large surfaces

All of these applications have large surfaces suitable for displaying images and allow longer throw distances while providing sufficient room and distance for audiences watching the presentation. High-brightness projectors are required to fill the large surfaces with light and to achieve higher levels of reflected light.

Reflectivity

It is hard to modify the reflectivity of outdoor objects onto which projections are being cast.

Brightness is key

Outdoor projection requires a lot of light to achieve sufficient contrast:

- a. Buildings do not have the same reflectivity features like a regular projector screen has. High brightness projectors offer a solution there for several reasons. First of all, the brightness they produce can compensate for the limited reflectivity the 'canvas' offers. Secondly, it may

- be possible to use fewer projectors when comparing to lower lumen output projectors, saving costs and simplifying installation.
- b. In reality an imaging object has non-uniform reflectivity. High-brightness projectors are able to lower their brightness output at any time to match multi-channel brightness uniformity, while low-brightness projectors are unable to increase their power to increase brightness output.

Besides the properties of outdoor imaging objects, ambient light is one of the factors that influences the performance. As it's not always possible to reduce ambient light, a viable alternative is to use a high-brightness projector that is able to compete with or overcome the effects posed by ambient light.

Constant brightness over time

Barco's Constant Light Output (CLO) functionality guarantees peace of mind. It delivers constant and consistent levels of brightness and color over time. When using a multi-channel setup, it is easy to set the brightness output of each projector (channel) to maintain a uniform level of brightness across the entire system. The uniform CLO over a certain period eliminates uncontrolled light output that may be caused by the natural ageing of the light source.

Thanks to the new laser light source, brightness decay is very gradual; it takes 20,000 hours of use to reach a level of 50% of the initial brightness. For example, by using CLO and setting the target to 80% of the maximum light output, you're able to operate for 15,000 hours with a consistent, constant light output. You can monitor the brightness produced in the projector at any time. This means you can now measure, adjust and maintain a fixed brightness level over extensive periods of time.

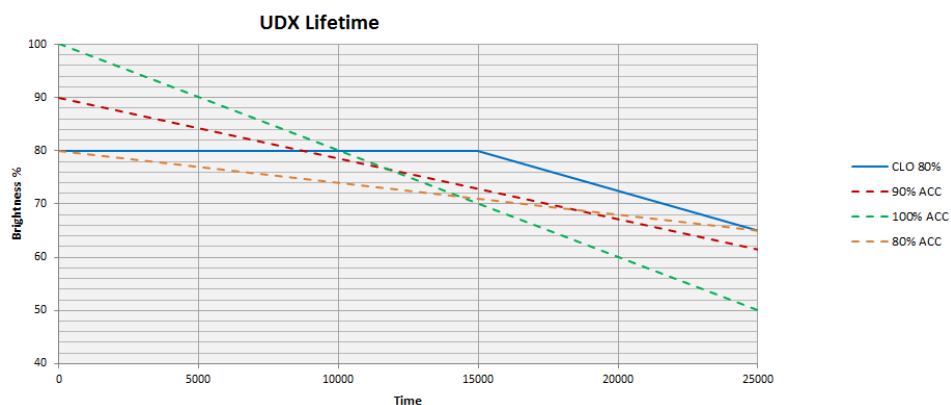

Example of Barco UDX projector's lifetime when using CLO

Renowned Barco colour performance

The colour performance of Barco's high-brightness laser projectors when in full-brightness mode is equivalent to the renowned Xenon quality of Barco's HD series (HDX, HDF). Other systems have needed to sacrifice brightness in order to reach similar colour standards on 30,000lm units; Barco does not compromise on colour to reach high-brightness levels of up to 32,000lm.

Other benefits of laser illumination

Longer lifetime and constant brightness over time

- Barco's high brightness projectors can deliver specific brightness levels without sacrificing the lifetime of the light source.
- Due to the nature of laser technology, the brightness decay of laser projectors is very gradual. Therefore, laser projectors can achieve consistent and constant levels of brightness over longer periods of time. Moreover, reducing the brightness a little has an exponential impact on the lifetime of the light source.

Higher power efficiency

- The maximum power consumption of the UDX-4K32 is only 3,100W at a brightness of 31,000lm. If you wished to reach the same brightness on a lamp projector with, for example, Xenon lamps, the power consumption would reach levels of approximately around 4,800W. When using UHP lamps, the power consumption would reach approximately 4,400W.
- The electricity cost is lower when using laser projectors.

Flexible setup orientation

- Projection mapping is all about the beauty and story of a building or object. The projectors enabling this vibrant image from a distance and can meet installation restrictions with regards to the location where they can be installed and how they can be installed. When using lamp projectors, one always has to consider the limitations on the installation angle to ensure that the units will work properly. With the introduction of laser projection, the installation options have increased tremendously: any angle, 360° installation freedom opens up much more installation flexibility and ease of use than ever before.
- Thanks to Barco's sophisticated cooling technology, its high-brightness projectors do support flexible setup orientation with efficient cooling.

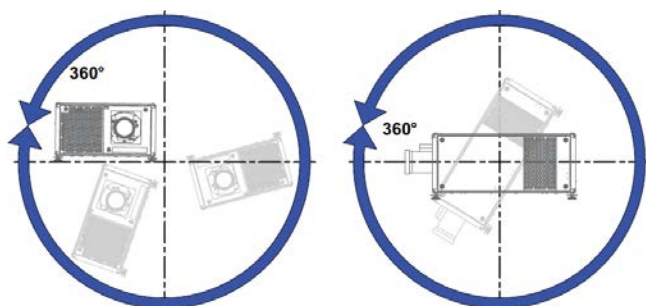

No image flickers or sudden lamp failures (inherent redundancy)

- Use a laser light source that incorporates multiple lasers. They provide inherent redundancy.

Why 4K resolution is growing in popularity?

Content is king

- There is no doubt that 4K content creation is becoming increasingly popular today, in both the consumer and professional markets. Even laptop computers have Retina Displays, and the graphics cards of current PCs are able to present 4K images. In other words, 4K projection systems are definitely required to faithfully reproduce content.

Number of projectors can be reduced

- Cost saving: 4K is four times as detailed as 2K, if the same pixel size is broadcast. As such, there is only need for one 4K projector instead of four 2K projectors; this reduced need is intrinsically linked to reductions in costs.
- Easy installation: there is less blending work required and it is easy to position projectors and align the system.
- Higher pixel efficiency and brightness: with a smaller blending zone, it's possible to avoid pixel and brightness waste.

Higher image quality with more detailed information

4K projection delivers smaller pixels than 2K projection when working on the same surface.

There are several forms of 4K projection currently on the market.

- DCI 4K (4096x2160) is a digital cinema specification with an aspect ratio of about 17:9.
- In the ProAV industry, the aspect ratio is 16:10 or 1920x1200. 4K is therefore 3840x2400.
- 4K UHD is four times that of HDTV (1920x1080), approximately 3840x2160.

	4K	3840 x 2400	16:10	9.2
	4K UHD	3840 x 2160	16:9	8.3
DCI	4K	4096 x 2160	17:9	9.1
	WUXGA	1920 x 1200	16:10	2.3
	HDTV	1920 x 1080	16:9	2.1
DCI	2K	2048 x 1080	17:9	2.2

4K UHD is the most common source to achieve standards four times those of HD, resulting in 2160 pixels.

The importance of all-glass, high-quality lenses

Compared to indoor projection, outdoor projection has several specific characteristics relating to long throw distances and large projection surfaces. The lens options are the key to flexibility in the design and installation of the setup.

Projection distance, throw ratio and screen width

The throw ratio is defined as the distance measured from the end of the lens to the projection screen, divided by the width of the image. The minimum throw distance is determined by the lower end of the focus range of the lens.

The correlation between screen width, throw ratio and projection distance is:

- Projection distance = screen width x throw ratio

- to calculate the width of a screen when the lens is at a certain distance:
- width = distance / throw ratio
- Each lens has a range of throw ratio; for example from 7.5-11.2. This means the projector is able to be used for screens with widths of 7.5x and 11.2x.

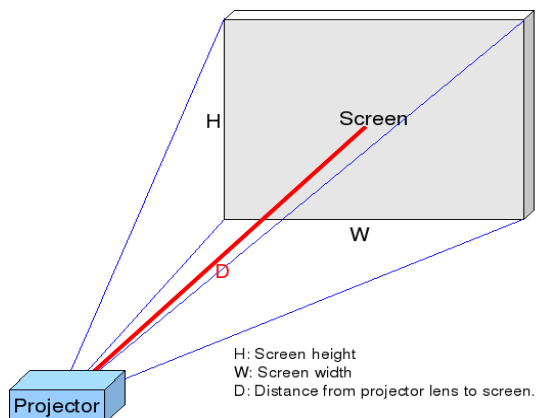

The importance of varied throw ratios of optional lenses

- The coverage of lenses' throw ratios is one criterium in the choice of lens. Barco offers a wide variety of all-glass lenses. Barco TLD+ lenses have throw ratios covering anything from 0.40 to 11.2. The range includes about 10 lenses.

Note: Throw ratios can differ depending on the size of the DMD chip used in the projector. As the parameters of the throw ratio of a lens are different for different sizes of DMD chip or projection output resolutions, please use the Barco lens calculator to calculate the actual specifications for each setup.

Focus range

Every lens has a focus range or specific throw distance at which the lens performs optimally.

- For example, a lens with a focus range of 2m-15m offers the best and most focused image when the projector is 2-15 metres from the screen.
- The projected image cannot be brought into focus if the throw distance is outside the focus range, especially when the distance is too short.

Lens shift

- The lens can be shifted relative to the DMD (P). This results in the image on the screen (Off-Axis) shifting.
- A 100% shift means that the centre point of the projected image is shifted by half the screen size.
- In other words, the centre point of the projected image shifts together with the outline of the image in an On-Axis projection. Due to mechanical and optical limitations, it's advisable to keep shift values within the field of view (F) as illustrated below.
- Within these shift ranges, the projector and lens perform to high standards.

- Configuring the projector outside these shift ranges will result in a slight decline of image quality. Typically, it results in dark corners.

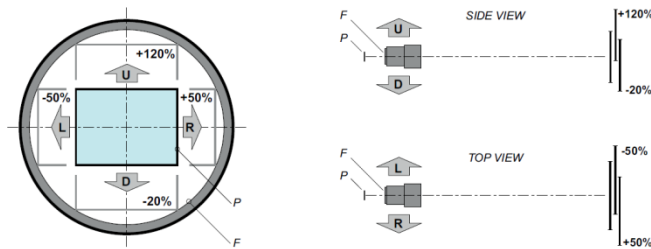

Lens mechanism

One major benefit of a high-quality projector with qualitative lenses is the quick zoom/focus/shift functionality that allows for accurate, realtime manipulation. Without this benefit, it may take considerable time for an adjusted image to become visible.

Barco's projector is equipped with a step motor for lens mechanisms that offer faster and accurate zoom/focus/shifts, and a lens position memory feature that saves pre-set lens positions, including the position of zoom/focus/shifts so that users can quickly recall their different setup.

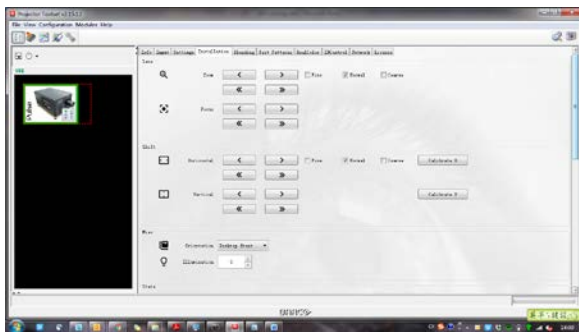

Barco powerful electronics platform: Barco Pulse

Next to its excellent optical and mechanical performance, the beating heart of a projector is undoubtedly its electronics platform. Barco Pulse is the brand new electronics platform for all Barco new generation projectors.

Barco Pulse is the 4K electronics backbone that's integrated in all new projection platforms. It offers an intuitive interface and flexible, user-friendly, embedded control software. Its unique Single Step Processing (SSP) technology enables our projectors to achieve 4K Ultra High Definition (UHD) resolution in only one step. This results in a sharper image, less latency, and less dark time than comparable solutions on the market.

Future-proof video interfaces

Multiple video input interfaces with the latest protocols to provide flexible connectivity, supporting, for example, the latest HDMI2.0, DP1.2, Quad SDI, HDBase-T, etc.



Image 5-6

- 1 Quad 3G SDI channel A Input
- 2 Quad 3G SDI channel B Input
- 3 Quad 3G SDI channel C Input
- 4 Quad 3G SDI channel D Input
- 5 DisplayPort Input
- 6 HDMI Input
- 7 HDBaseT Input 1
- 8 HDBaseT Input 2

The yellow LED lights up when valid input sync is detected.
The green LED lights up when the input is selected.

Easy control and communication

The electronics platform offers various ways to communicate with the projector through its RS232 serial port, wired Ethernet cable, WiFi, GSM, DMX and remote controls using either IR or XLR.

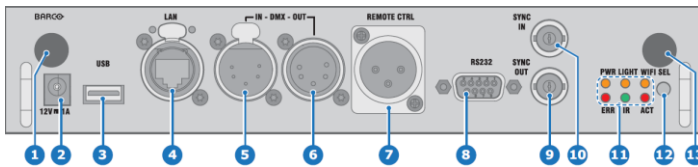
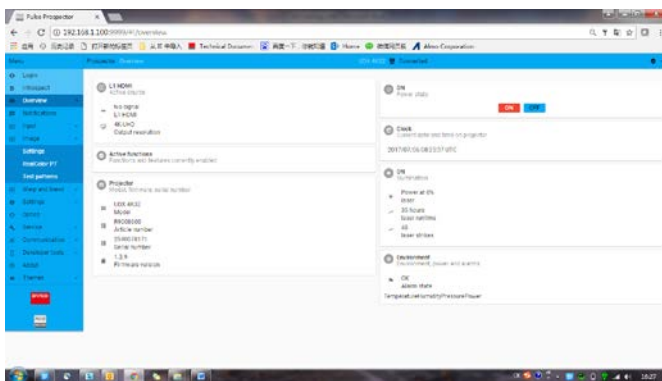

Image 5-8

- 1 WiFi antenna for wireless IP (optional)
- 2 12V 1A output
- 3 Firmware update / USB backup custom settings
- 4 10/100 base-T for external control over IP and Art-Net
- 5 DMX interface input
- 6 DMX interface output
- 7 XLR input for wired projector control
- 8 RS232 for serial communication
- 9 Sync Out 3D
- 10 Sync In 3D
- 11 Status lights
- 12 IR receive sensor
- 13 GSM antenna input (optional)

Users can control the projector using the Barco Projector Toolset application (PToolset) software, by accessing the embedded webserver via the web browser, the keypad with LCD display on the projector, or of course, with the traditional remote control with an OSD (on Screen display) menu, or even with a light console that incorporates DMX protocol, etc. Barco Projector Toolset is also available as an app for Android and iOS devices.



Embedded webserver of projector

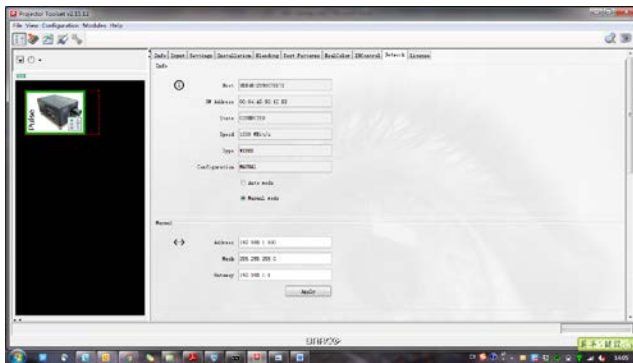

Barco projector toolset application software

- Faster image processing with no additional latency is very important eg. to maintain accurate lip sync.
- You can read a more detailed description on the advantages of Barco's SSP and the 4KUHD processing technology in Barco's "4KUHD explained" whitepaper on barco.com.

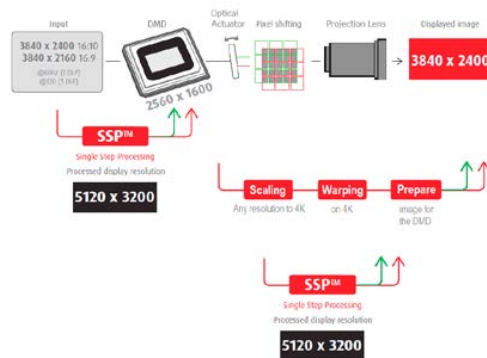

Real-time warping for anything up to 4K image quality

Real-time and high-quality warping and blending on 4K images allows high quality mapping on asymmetric surfaces. Using the Barco Projector Toolset software or by accessing the projector's embedded webserver, you can achieve real-time warping on anything up to 4K imaging, not only with simple blanking, four corner and BOW (both symmetric and asymmetric), but also with anything from 2x2 up to 33x33 points with real-time geometric correction that maintains sharpness and content details. Easy user interfaces enables quicker installation and correction and ensures to maintain sharpness and content details at all times.

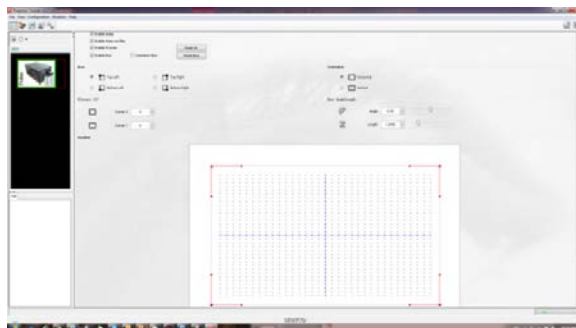

User-interface for corners and BOW

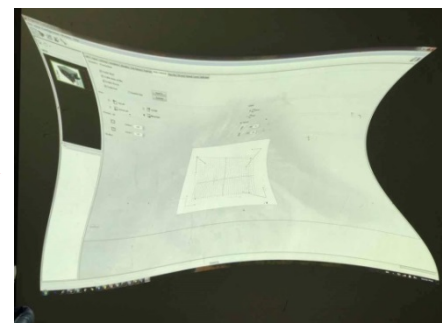

Real time presentation on the screen

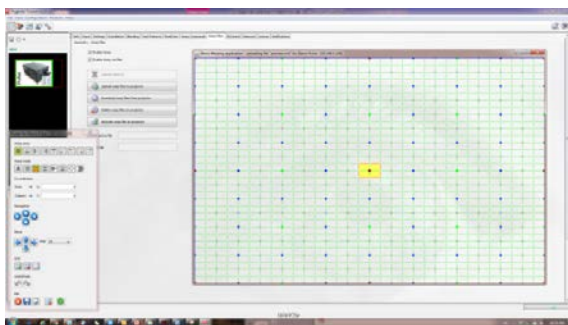

User-interface for 33x33

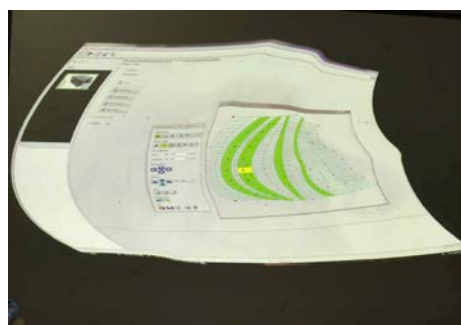

Real time on screen 33x33

Summary

For outdoor projection an projection mapping in general, there are a number of considerations that should be taken into account during the design and installation process:

- Image quality parameters
 - Content resolution: content is king and the foundation of a project mapping presentation. The total resolution of the mapping surface is calculated based on it, and it is also used to break down the resolution for each channel/projector.
- Properties of imaging objects
 - Shape and size of projection surface, reflectivity, and focus plane etc. to delimit channels.
- Capabilities of the image generator (media server + projectors).
 - Symmetric or asymmetric projection?
 - Pre-distortion? Warping?
 - Blending? Number of Channels? Resolution/channel?
- Projector selection and system design:
 - Brightness
 - Resolution
 - Lenses
 - Positioning (installation angle)
- Installation and projection restrictions/obstacles.
- And optimal viewing position and viewing distance

The higher the performance of the projector, the easier it is to simplify an installation that may otherwise become a costly, needlessly complex solution. It also results in maximum flexibility and usability for the designer and the installation team and delivers the best image and as such, a superior audience experience.